

Touch

GSSG
CERAMIC DESIGN

L'azienda *Company Profile*

GSG Ceramic Design considera elementi base del suo percorso creare ceramiche che possano, con la loro forte personalità, creare/evocare stimolanti suggestioni.

La continua ricerca estetico-tecnica ha portato questa piccola azienda ad essere conosciuta internazionalmente con una ben precisa immagine. Questo risultato è dovuto sia al talento artistico di Massimiliano Abati per la sua innovativa proposta formale sia alla professionalità dell'Azienda maestra nell'innovare costantemente nel solco di una grande tradizione tecnica. Gli oggetti prodotti sono esclusivi e carichi di significati intellettuali. Il loro utilizzo conduce a scenari estetici inesplorati.

Piccole ma grandi opere aperte.

GSG Ceramic Design considers basic elements of his personal path to create ceramics that they can with their strong personalities create / evoke stimulating suggestions.

The continuous aesthetic and technical research has led this small company to be known internationally with a very specific image.

This result is due both to the artistic talent of Massimiliano Abati for his innovative formal proposal and to the company's professionalism with his constantly innovating in the wake of a great technical tradition.

The produced items are exclusive and plenty of intellectual meanings.

Their choice leads any user to aesthetic scenarios still unexplored. Small but big open works.

GSGi
CERAMIC DESIGN

Processo produttivo Manufacturing process

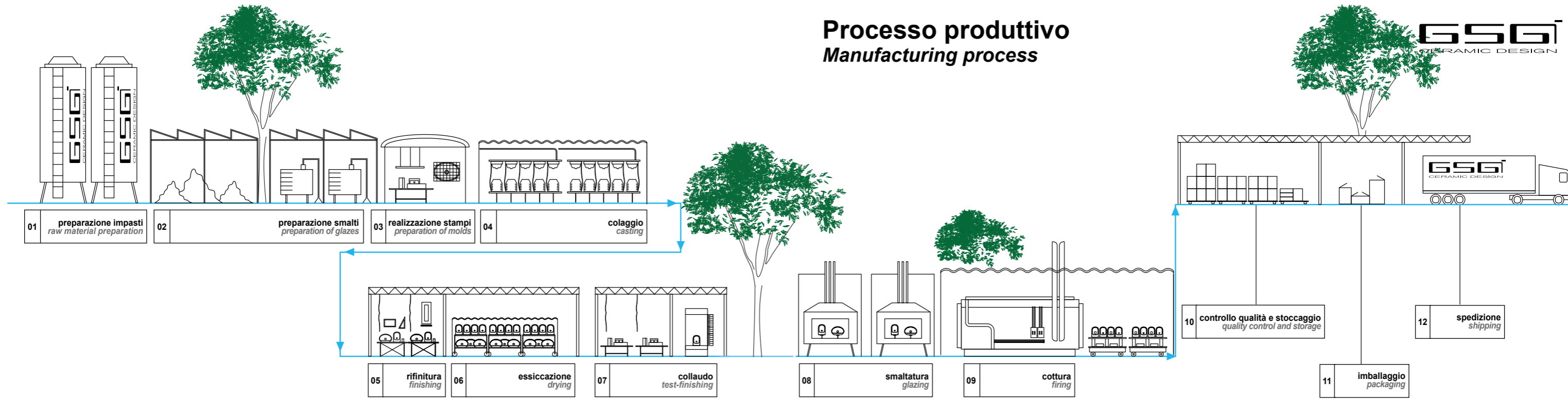

01	02	03	04	05	06	07	08	09	10	11	12
preparazione impasti raw material preparation	preparazione smalti preparation of glazes	realizzazione stampi preparation of molds	colaggio casting	rifinitura finishing	essiccazione drying	collaudo test-finishing	smaltatura glazing	cottura firing	controllo qualità e stoccaggio quality control and storage	imballaggio packaging	spedizione shipping

L'utilizzo di materie prime di primaria qualità, permettono di ottenere gli impasti comunemente usati per la ceramica sanitaria: Vetro China, ottenuta con l'utilizzo di alte percentuali di caolino e quarzo, che la rendono più pura e fine, e Fire Clay, ottenuto utilizzando meno caolino e più materiali inerti.

L'alta qualità degli smalti adoperati è garantita dai continui tests a cui vengono sottoposti, per esprimere al meglio la corretta sintonia con il supporto ceramico, l'adeguata corrispondenza della tonalità di colore e le caratteristiche di resistenza che le normative impongono.

GSG Ceramic Design utilizza solo gesso di altissima qualità per la realizzazione dei suoi stampi. Il gesso permette, mediante il principio di assorbimento d'acqua, di creare le condizioni affinché il prodotto, nella sua prima fase di lavorazione, possa essere facilmente isolato.

Gli impasti precedentemente preparati, Vetro China o Fire Clay, vengono iniettati, manualmente o con l'ausilio di appositi macchinari, all'interno degli stampi in gesso mediante i quali, per mezzo del principio di assorbimento d'acqua, si ottiene il prodotto preformato avente il giusto spessore della materia.

La prima fase di rifinitura è a cura di mastri esperti che, manualmente, rimuovono ogni imperfezione dovuta ad esempio ad impasto eccedente nelle giunture tra i pezzi dello stampo o ad altre cause nel processo di modellazione. Eventuali articoli non idonei agli alti standard GSG saranno rimossi dalla produzione e riutilizzati come materiale da reimasto.

Per ridurre in modo importante il processo di asciugatura dei prodotti senza tuttavia comprometterne l'integrità cioè senza provocare fessurazioni, essi vengono trasportati in un essiccatoio automatico dove viene forzata in modo controllato una rapida e significativa perdita d'acqua e quindi di peso.

I prodotti vengono sottoposti ad una ulteriore fase di rifinitura, sempre manuale, ancora più attenta e approfondita, al fine di ottenere prodotti privi di imperfezioni.

La smaltatura, effettuata manualmente da mastri smaltatori, è applicata a tutte le superfici esterne ed interne di ogni articolo, evitando accuratamente che in ogni prodotto rimangano parti non smaltate.

I prodotti smaltati attentamente caricati sulle strutture vengono inviati al forno per la cottura. In GSG il ciclo di cottura ha una durata di ca. 22 ore e segue un preciso programma di fasi tutte determinanti per l'ottenimento di un risultato finale ottimale. I prodotti sono pre-riscaldati, quindi portati lentamente alla temperatura di cottura che in GSG è 1250° C., quindi passano alla fase di "permanenza" ed infine al raffreddamento.

I prodotti selezionati e corrispondenti agli standard GSG vengono stoccati nel nostro magazzino. I prodotti sono suddivisi per serie, tipologia e colore o decorazione. Tutto il magazzino è controllato on time dal nostro sistema di gestione per poter rispondere tempestivamente e correttamente alle richieste della clientela.

Ogni articolo viene singolarmente scatoletto, posto sul pallet e avvolto da una pellicola protettiva in PVC termoretraibile.

I nostri prodotti sono tutti pallettizzati per la loro sicurezza e facilità di trasporto. GSG è in grado di caricare pallett su qualsiasi mezzo di trasporto su gomma con pianale e di predisporre containers sia di 20' che 40'.

The use of finest quality raw materials, permits us to use fewer inert materials: Vitreous China is made with high percentages of kaolin and quartz, making it purer and finer. Fire Clay, is obtained using less kaolin and more inert materials.

The high quality of glazes used is always being tested continually giving a correct harmony for the ceramic production, a guarantee of colour tones and resistance that international standards require.

GSG Ceramic Design uses only the highest quality plaster for the construction of its molds. Plaster allows, by means of the principle of water absorption, to create the conditions so that the product, in its first stage of processing, it can be easily isolated.

Vitreous China or Fire Clay previously prepared, are injected, manually or with the aid of suitable machinery, to the interior of plaster molds, by means of the principle of water absorption, the product is obtained prefinished and having the right thickness of the material.

The first stage of finishing is curated by expert masters that, manually, remove all imperfections due for example to excess dough in the joints between the pieces of the mold or other causes in the modeling process. Any items not suitable to the GSG high standards will be removed from production and reused as material for re-mix.

To drastically reduce the drying process of the products without compromising their integrity that is, without causing cracks, they are transported in an automatic dryer where it is forced in a controlled manner a rapid and significant loss of water and therefore weight.

Any item it's subjected to a further step of finishing, always manual, even more careful and thorough, in order to obtain products free of imperfections.

Glazing, hand made by master glazers, is applied to all external and internal surfaces of each item, carefully avoiding that in every product remain unglazed parts.

The glazed products carefully loaded on the wagons are sent to the kiln for firing. In GSG the firing cycle has a duration of about 22 hours, following a precise schedule of all phases determinants for obtaining an optimum end result.

The products are pre-heated, then slowly brought to the firing temperature which GSG is 1250 ° C., then pass to the phase of "permanence" and finally to the cooling.

Products selected and meeting the GSG standards are stored in our warehouse. The products are subdivided in series, type and color or decoration. All warehouse it's controlled on time by our management system in order to respond promptly and correctly to our customers' requests.

Each item is separately packed in a single cardboard box, placed on pallets and wrapped in protective PVC shrink film.

Our products are all palletized for their safety and ease of transport. GSG is able to load pallets on any means of transport on the platform with rubber and to prepare both containers 20' to 40'.

Stabilimento



Factory

Plus tecnologici per la collezione TOUCH
 Technological Plus for TOUCH collection



Plus wc TOUCH

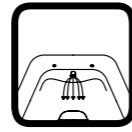

wc bidet



saving water

Plus tecnologici per la collezione TOUCH
 Technological Plus for TOUCH collection

Plus coprivaso - seat cover TOUCH



termoindurente
thermoindurent



avvolgente
wrapover

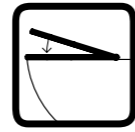

soft close

Caratteristiche lavabi
 Washbasins features

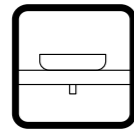

appoggio
countertop

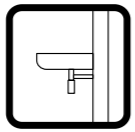

sospeso
wall-hung

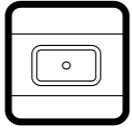

free standing

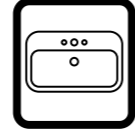

monoforo - tre fori
one hole - three holes

06 _____ Collezione / Collection Touch

48 _____ Schede tecniche Touch e lavabi
 Technical measurements Touch
 and washbasins



Smart clean

Sistema di scarico Smart Clean
Intelligent flushing system

SMART CLEAN è il nuovo ed innovativo sistema di scarico realizzato da GSG Ceramic Design. Grazie alla forma della sezione del vaso, l'acqua compie un percorso rotatorio che garantisce una pulizia più efficace. Con l'eliminazione della brida l'acqua viene convogliata direttamente sull'area interessata, evitando formazioni batteriche in aree nascoste e difficilmente raggiungibili. Il sistema SMART CLEAN è disponibile nelle versioni LIKE, BRIO e TOUCH.

SMART CLEAN is the new and innovative flushing system made by GSG Ceramic Design. The particular form of the section of the WC makes the water flush in rotatory motion which guarantees a more effective cleaning. With the elimination of the rim, water is forced directly to the proper area, avoiding bacterial formations in hidden areas and difficult to reach. SMART CLEAN system is available in versions LIKE, BRIO and TOUCH serie.

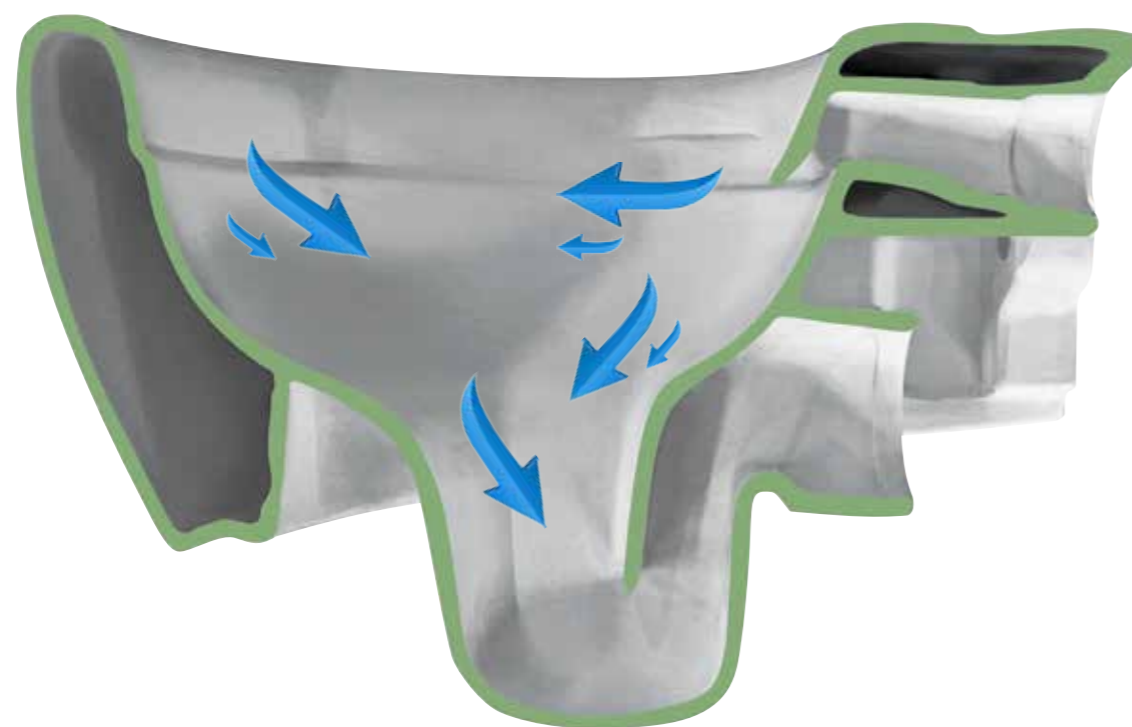

Wc Touch Smart Clean



Cod. TOWC01SC
Wc Touch a terra
Wc Touch back to wall



Cod. TOWCSOSC
Wc Touch Sospeso
Wc wall-hung Touch



Cod. TOWC01SC
Wc Touch a terra
Wc Touch back to wall

Cod. TOCIMBL
Cassetta a colonna Touch
Touch column cistern



Collezione Touch



Concept Touch

Rendere tattile l'ambiente bagno, è l'obiettivo di Gsg Ceramic Design, che offre ancora un mood fortemente caratterizzato. Touch è forma a servizio dell'acqua, modellata dall'acqua, fornita all'uomo come oggetto poetico: per chi cerca significati nelle forme, Touch diventa oggetto in divenire, sempre coerente al passaggio del tempo, mai stanco di servire il corpo e la mente. E' la ricerca della naturalezza, il movimento delle forme, la volontà di circondarsi di forme regalate dalla natura che diventa archetipo, un modus vivendi diventato l'unica via per vivere in un'esatta coerenza. Il gesto plastico che ricorre su tutta la gamma, è quello di creare quasi a livellomanuale, una sede per accogliere l'acqua e modellare la materia per servirsene in maniera non traumatica: tutto ciò conferisce agli oggetti un contenuto artigiano d'altri tempi che esula dalle forme altamente industrializzate di cui ci siamo circondati. Il messaggio quindi è quello della riscoperta di oggetti che possano superare la sfida del tempo attraverso una riacquisita onestà delle forme e della loro destinazione d'uso.

GSG Ceramic Design aims at creating tactile sensations in the bathroom setting and offers a strongly marked style. Touch is matter for water and shaped by water, offered to man in the form of a poetical object: for those who look for significance in shapes, Touch becomes an ever-changing object, always consistent with the passing of time and ready to serve body and mind. It is a search for naturalness, the movement of shapes, the desire to surround oneself with shapes offered by Nature that becomes an archetype, it is a modus vivendi, the only way of living in absolute consistent harmony. The plastic gesture characterising the whole set is the almost manual moulding of a place to house water and shape matter in order to reuse it in a non traumatic way. Objects thus take on an old-fashioned craftsmanlike value which has nothing in common with industrialized shapes we are usually surrounded by. The underlying message is: let's rediscover the taste for objects that can win the challenge against time through renewed integrity of shapes and their intended use.

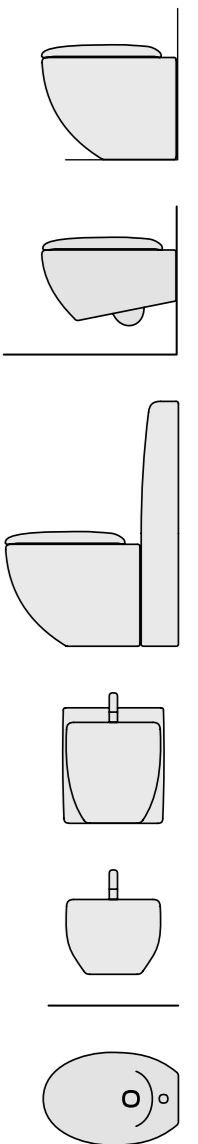

Touch

Versione a terra *Back to wall*



Touch

Morbidezza ed Unicità
Softness and Uniqueness



Wc Touch a terra
Wc Touch back to wall
Cod. TOWC01SC

Bidet Touch a terra
Bidet Touch back to wall
Cod. TOBI01

Touch



Touch



Touch



Touch

Morbidezza ed Unicità
Softness and Uniqueness



Wc Touch a terra
Wc Touch back to wall
Cod. TOWC01SC

Bidet Touch a terra
Bidet Touch back to wall
Cod. TOBI01

Touch

Versione sospesa Wall-hung



Touch

Morbidezza ed Unicità
Softness and Uniqueness



Bidet Touch sospeso
Bidet Touch wall-hung
Cod. TOBISO

Wc Touch sospeso
Wc Touch wall-hung
Cod. TOWCSOSC

Touch



Touch



Touch

Versione monoblocco *Monoblock*



Touch



Touch

Morbidezza ed Unicità
Softness and Uniqueness



Wc Touch a terra
Wc Touch back to wall
Cod. TOWC01SC

Cassetta a colonna Touch
Column cistern Touch
Cod. TOCIMBL

Complemento per bidet Touch
Panel to suit bidet Touch
Cod. TOCOBI

Bidet Touch a terra
Bidet Touch back to wall
Cod. TOBI01

Touch





Touch

Touch

Collezione lavabi
Washbasins collection

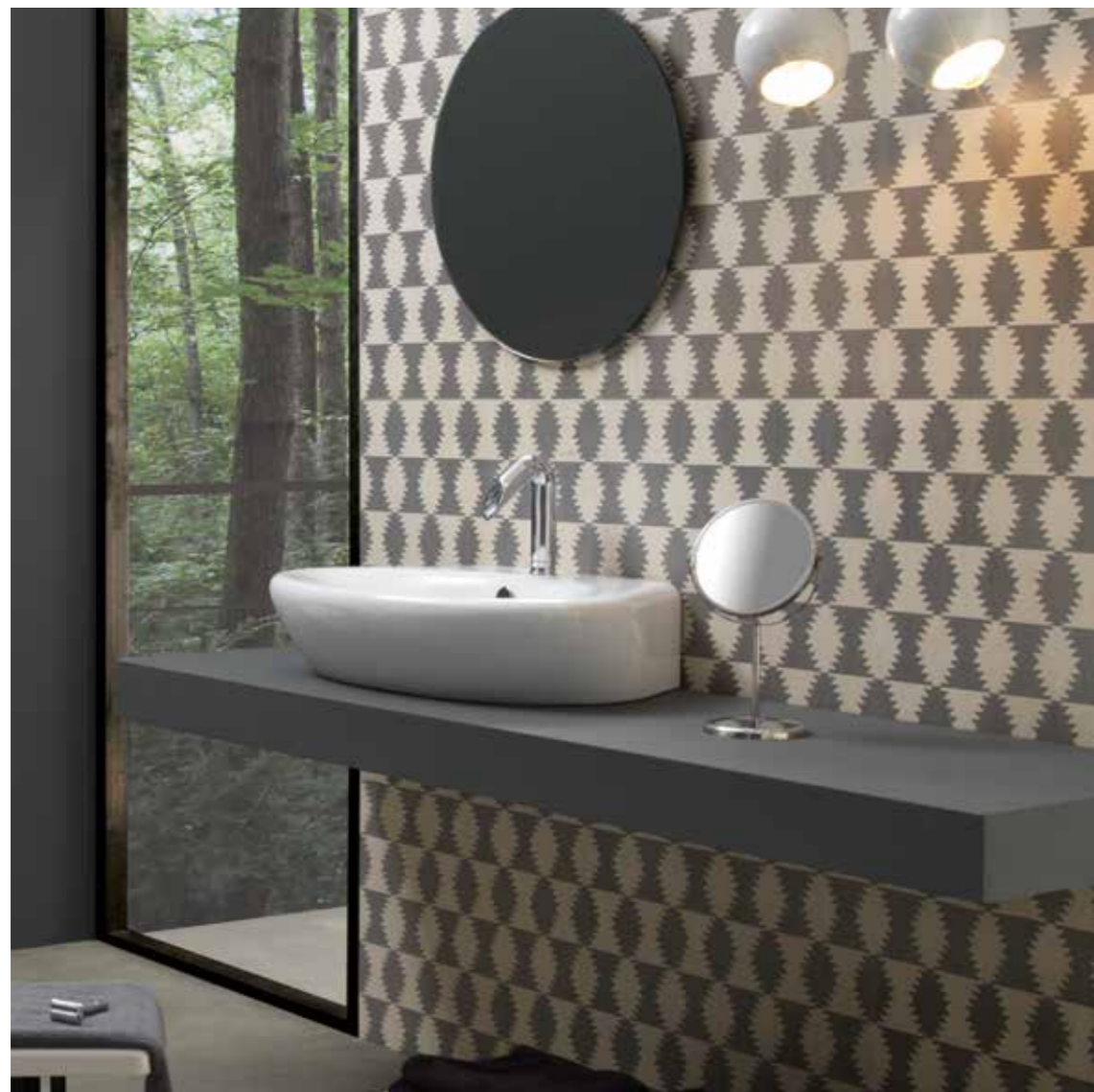

Lavabo Touch 70
Touch washbasin 70
Cod. TOLAV70



Touch 47x49,5
Cod. TOLAV47



Touch 70x49,5
Cod. TOLAV70



Touch 90x45
Cod. TOLAV90

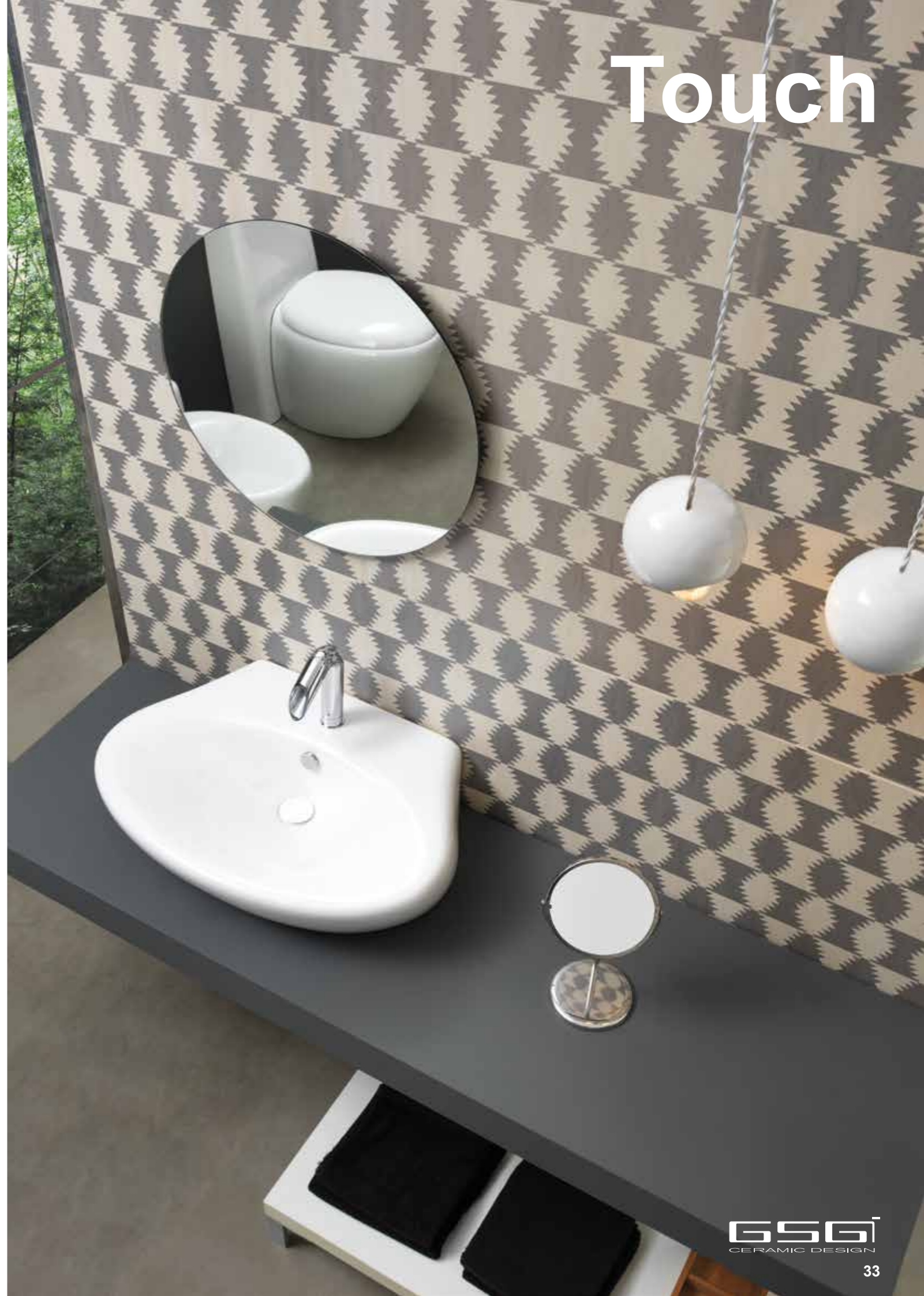

Touch



Touch

Touch



Touch

Morbidezza ed Unicità
Softness and Uniqueness

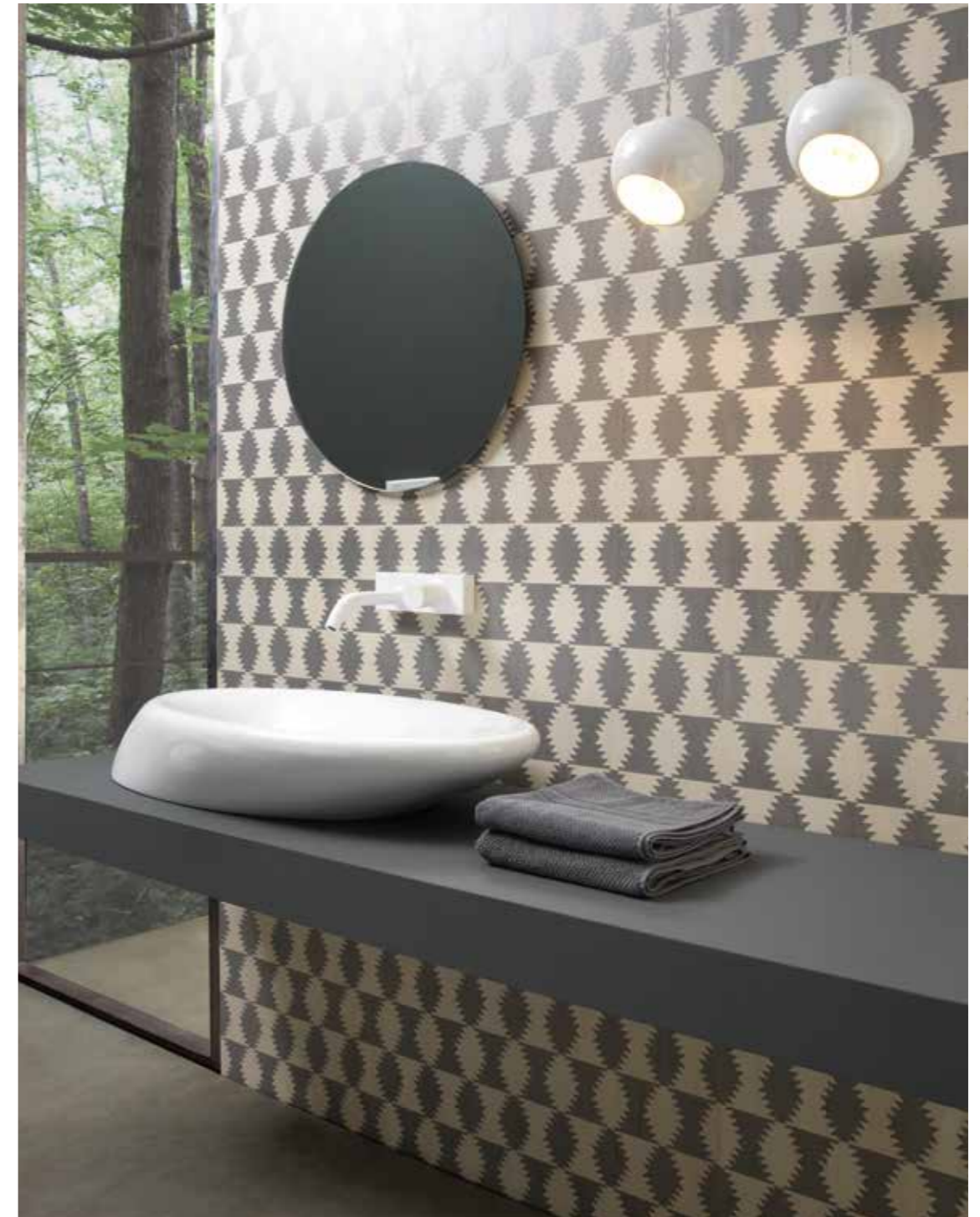

Lavabo Touch 90
Touch washbasin 90
Cod. TOLAV90

Touch



Touch

Collezione lavabi
Washbasins collection



Lavabo Touch 47
Touch washbasin 47
Cod. TOLAV47

Touch



Touch



Touch

Vasca Bathtub



Vasca Touch centro stanza cm 205
Bath tub free standing touch cm 205
Cod. TOVA205

Touch

Morbidezza ed Unicità
Softness and Uniqueness



Wc Touch sospeso
Wc Touch wall-hung
Cod. TOWCSOSC



GSGI
CERAMIC DESIGN

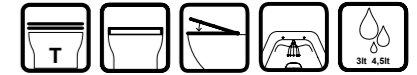

Wc Touch a terra Wc Touch back to wall
Bidet Touch a terra Bidet Touch back to wall

Ingombri Measure



COD TOWC01SC

COD TOBI01

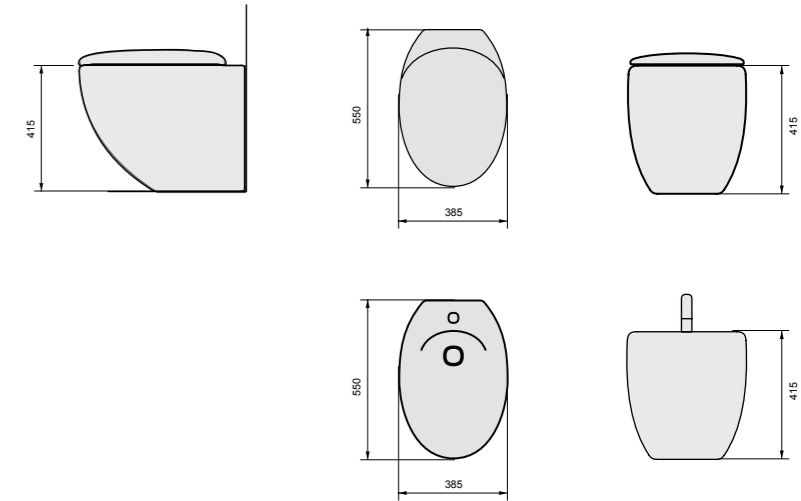

COD TOWCSOSC

COD TOBISO

Wc Touch sospeso Wc Touch wall-hung
Bidet Touch sospeso Bidet Touch wall-hung

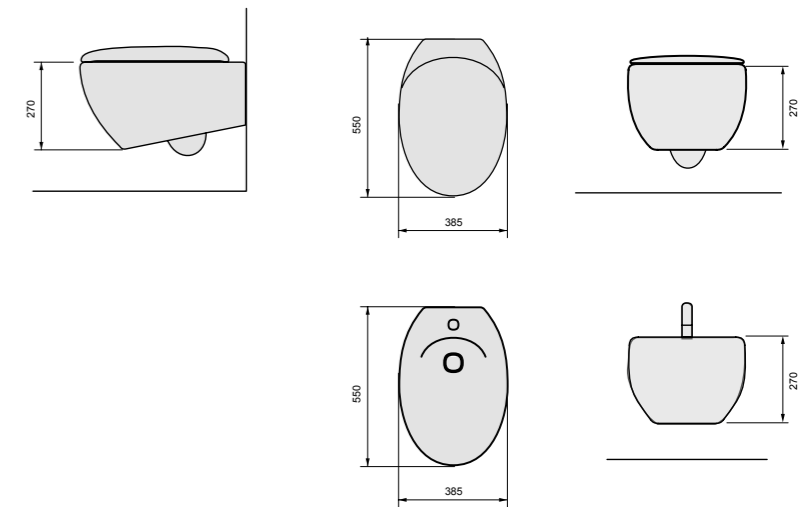

COD TOCIMBL
COD TOWC01SC

COD TOCOBI
COD TOBI01

Wc Touch a terra con cassetta a colonna Wc Touch back to wall with column cistern
Bidet Touch a terra con complemento Bidet Touch back to wall with panel

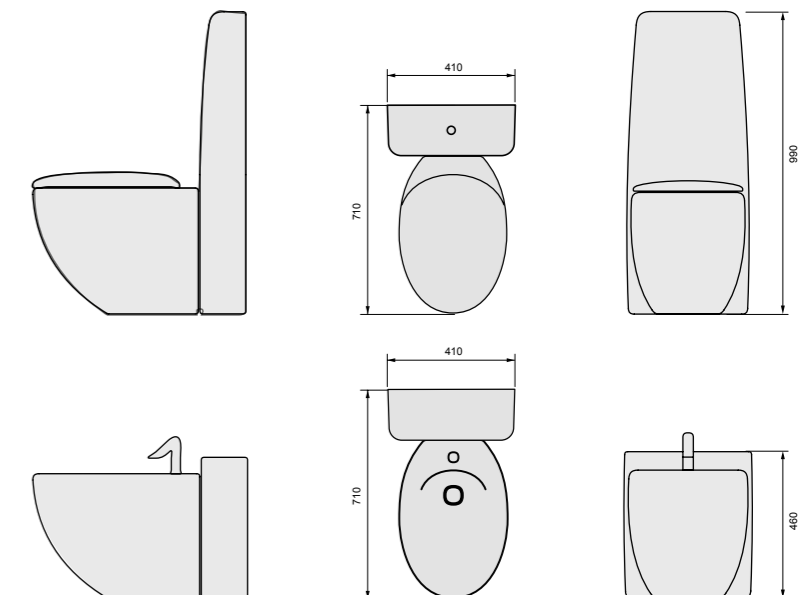

Touch



Lavabi Touch *Washbasins Touch*



Touch



Touch



Cod. TOLAV47
47x49,5x16,5



Cod. TOLAV90
90x45x15



Cod. TOLAV70
70x49,5x16,5



cod. TOWC01SC
Vaso Touch Smart Clean scarico a terra convertibile a pavimento mediante curva tecnica.
Wc Touch Smart Clean back to wall drain suitable for floor drain with technical elbow.

cod. TOWC01SC

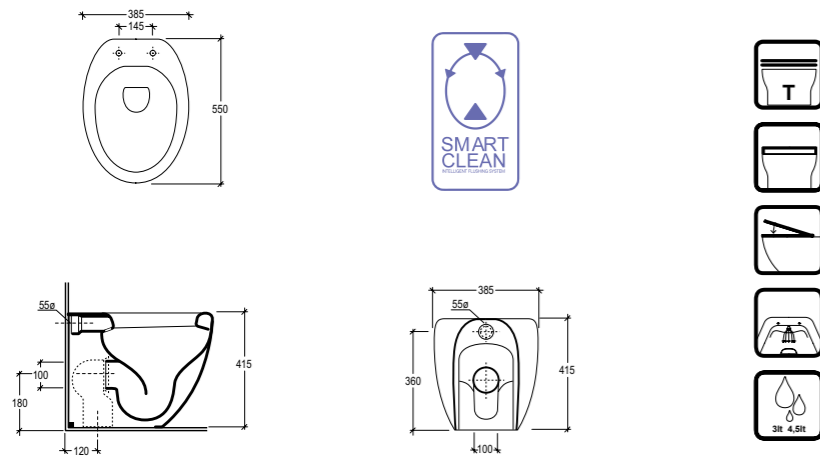

cod. TOWCSOSC
Vaso Touch Smart Clean sospeso
Wc Touch Smart Clean wall-hung

cod. TOWCSOSC

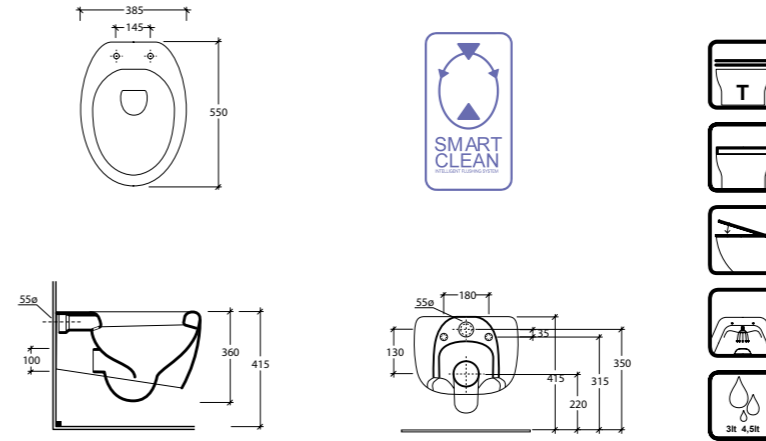

cod. TOBI01
Bidet Touch a terra monoforo (senza foro su richiesta)
Bidet Touch back to wall one hole (without hole on request)

cod. TOBI01

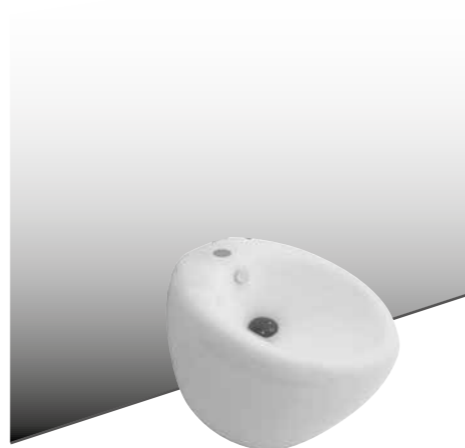
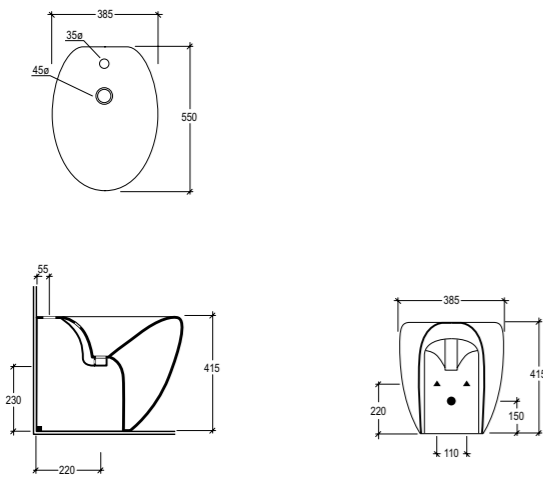

cod. TOBISO
Bidet Touch sospeso monoforo (senza foro su richiesta)
Bidet Touch wall-hung one hole (without hole on request)

cod. TOBISO

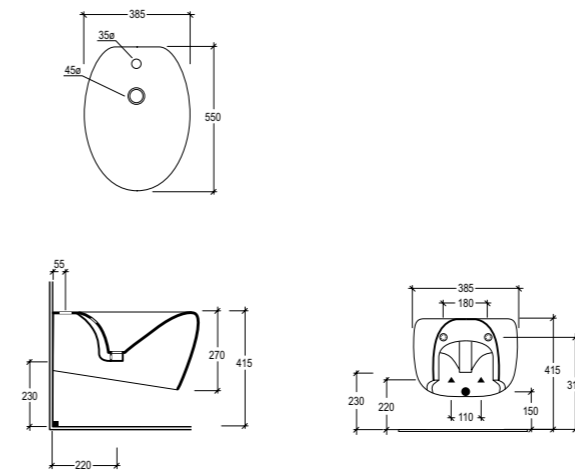

cod. TOWC01SC
Vaso Touch Smart Clean scarico a terra convertibile a pavimento mediante curva tecnica.
Wc Touch Smart Clean back to wall drain suitable for floor drain with technical elbow.

cod. TOCIMBL
Cassetta a colonna Touch
Touch column cistern

cod. TOCIMBL
cod. TOWC01SC

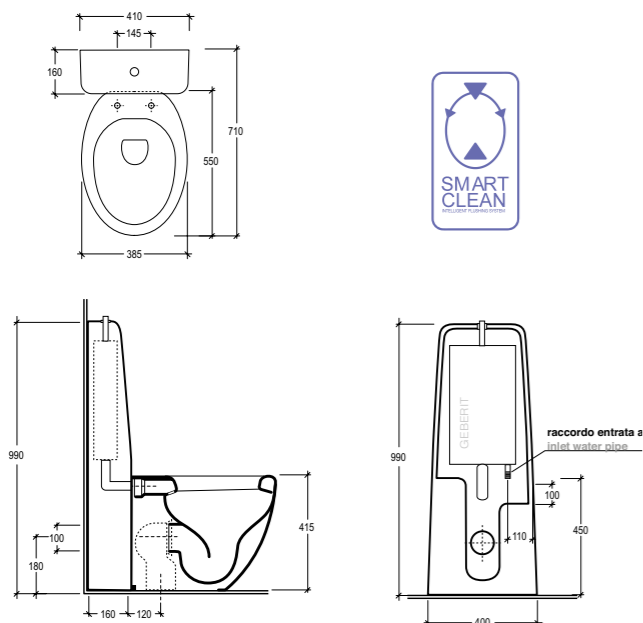

cod. TOBI01
Bidet Touch a terra monoforo (senza foro su richiesta)
Bidet Touch back to wall one hole (without hole on request)

cod. TOCOBI
Complemento per bidet Touch
Panel to suit bidet Touch

cod. TOCOBI
cod. TOBI01

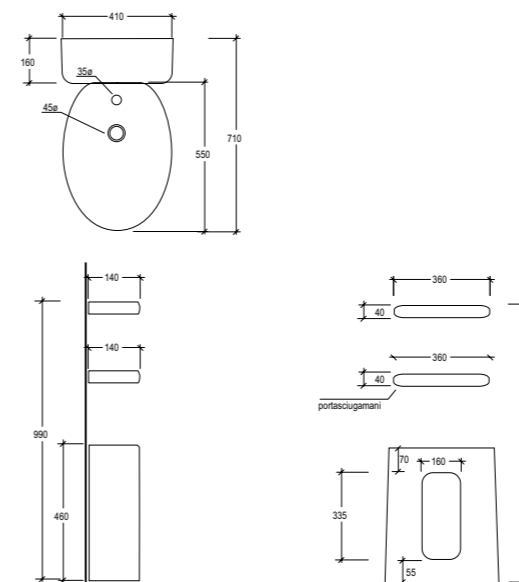

cod. TOLAV47
Lavabo Touch cm 47 monoforo (senza foro su richiesta).
Touch Washbasin cm 47 one hole (no hole on request).

cod. TOLAV47

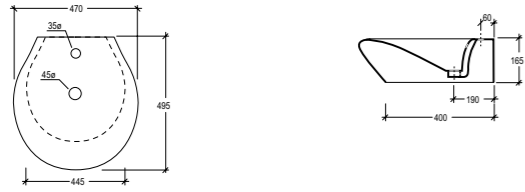

cod. TOLAV70
Lavabo Touch cm 80 monoforo (senza foro, tre fori su richiesta).
Touch Washbasin cm 80 one hole (no hole, three holes on request).

cod. TOLAV70

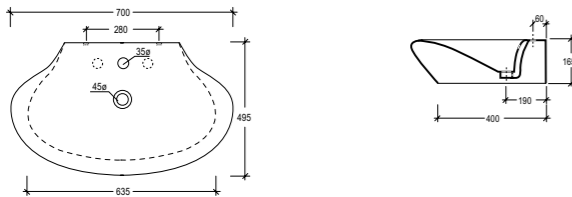

cod. TOLAV90
Lavabo Touch cm 90 senza foro.
Touch Washbasin cm 90 no hole.

cod. TOLAV90

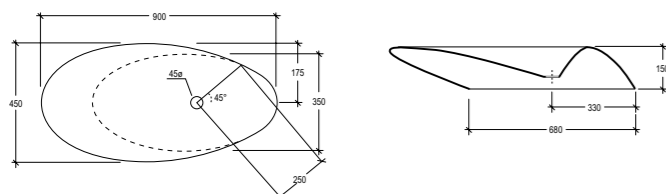

cod. TOVA205
Vasca Touch centro stanza in Pietraluce®
Bathtub Touch free standing in Pietraluce®

cod. TOVA205

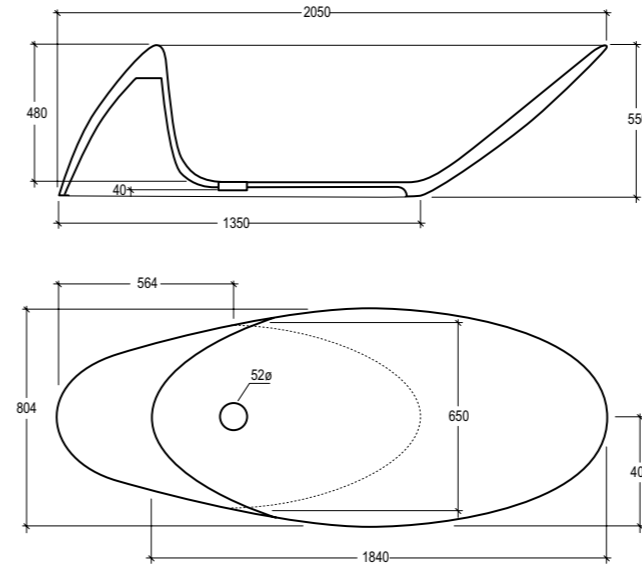

I Coprivater per i Wc Touch sono disponibili nelle versioni:
The Seatcovers Touch are available in the following models:

Avvolgente/Wrapover TOCOPRTI

Avvolgente Rallentato/ Wrapover Soft-Close TOCOPRTICR



LE MISURE INDICATE POSSONO VARIARE DEL 0.6% CIRCA, PER USURA STAMPI E PER VARIAZIONI DELLE CARATTERISTICHE TECNICHE DELLE MATERIE PRIME.

THE INDICATED SIZE COULD HAVE A VARIATION OF ABOUT 0.6% DUE TO THE USURE OF MOULDS AND VARIATIONS IN THE RAW MATERIALS.

GSG

CERAMIC DESIGN

Controllo Qualità - *Quality passed*

Ogni prodotto GSG Ceramic Design è sottoposto ai test di alta qualità di GSG Ceramic Design per essere conforme alla normativa UNI.

Any GSG Ceramic Design product is tested to match the GSG high quality controls and to be conform to UNI standards

Garanzia - *Warranty*

In osservanza della Direttiva Europea 1999/44/CE, recepita in Italia con D. lgs n. 206 del Codice di Consumo, GSG Ceramic Design riconoscerà eventuali difetti di conformità dei propri prodotti che si dovessero manifestare entro il termine di 24 mesi dalla loro vendita al cliente finale. L'unica spettanza di GSG Ceramic Design per tali pezzi è la loro sostituzione.

In observance of European Directive 1999/44/EC, implemented in Italy with Legislative Decree no. 206 of the Consumer's Code, GSG Ceramic Design will recognize any lack of conformity of their products that may be found within the period of 24 months from their sale to the end customer.

The only pertaining of GSG Ceramic Design for these pieces is their replacement.

Manutenzione - *Maintenance*

I sanitari GSG Ceramic Design con la loro smaltatura di altissima qualità possono essere puliti perfettamente con semplice acqua tiepida e sapone o detersivo non abrasivo. L'uso di detersivi abrasivi per la pulizia danneggia la smaltatura.

GSG Ceramic Design sanitary ware due to its high quality glazing can be perfectly cleaned with simple warm water and soap or non-abrasive detergent. The use of abrasives detergents for cleaning damage the glazing.

NOTES

Stampato su carta certificata proveniente da foreste gestite in modo sostenibile.

Printed on certified paper from sustainably managed forests.

Il marchio ed il logo GSG Ceramic Design sono marchi registrati.

GSG Ceramic Design diffida l'utilizzo dei propri marchi, loghi, nomi di dominio e ragione sociale anche dove non registrati.

I diritti di riproduzione di fotografie o testi contenuti in questo catalogo appartengono esclusivamente a GSG Ceramic Design.

Qualsiasi uso o riproduzione di fotografie o testi contenuti in questo catalogo senza il previo consenso di GSG Ceramic Design è espressamente vietata e soggetta alla normativa sul copyright intellettuale.

The brand and the GSG Ceramic Design logo are registered trademarks.

GSG Ceramic Design distrusts the use of its trademarks, logos, and company domain names even where not registered.

reproduction rights of photos or texts contained in this catalog belong exclusively to GSG Ceramic Design.

Any use or reproduction of photos or texts contained in this catalog without prior written approval of GSG Ceramic Design is expressly prohibited and subject to the laws on intellectual copyright.

GSG Ceramic Design si riserva il diritto di apportare upgrade tecnici ai propri prodotti senza alcun preavviso.

GSG Ceramic Design reserves the right to make technical upgrades to its products without prior notice.

MADE IN EU

GSG Ceramic Design s.r.l. Via Brunelleschi, 27
01033 Civita Castellana (VT) Italia
Tel. + 39 0761/515258 Fax + 39 0761/517444
www.ceramicagsg.it e-mail: info@ceramicagsg.it

Le nostre certificazioni:
Our certifications:

ISO9001 : 2008





GSG Ceramic Design srl
Via Brunelleschi 27 - 01033 - Civita Castellana (VT) - Italy
Tel +39 0761 515258 - 516194 - Fax +39 0761 517444
www.ceramicagsg.it - info@ceramicagsg.it